

**My way of chasing INGRESS and NOISE on the return path
of a CATV-HFC system.**

J. A. André (Andy) Lamarre
Senior member SCTE (USA).

Catv Expert

<http://www.catvexpert.com>

Catv Expert

www.catvexpert.com

Before we get going on this subject,

- 1- You require a special equipment at the headend and one in the field. These equipment must be capable of communicating between them.**
- 2- This project require a CATV-HFC system that operates, in both direction, the forward and the return path.**
- 3- The raison to do this project the way it is explained, is not to removed signal to customers unless it is absolutely necessary.**
- 4- This procedure will never get more than ONE customer without service during the hole operation.**
- 5- How this is done, is explained in this paper.**

To be able to do this operation, you'll require one (1) special equipment at the headend and two (2) in the field.

The instruments that are used for this project are:

- * Trilithic 9581-SST located in the headend.
- * In the field a Trilithic 860-DHPi with the option : SSR installed
- * A passive equipment call I-STOP.



9581-SST



I-STOP



860-DHPi

Headend with the TRILITHIC 9581-SST installed.

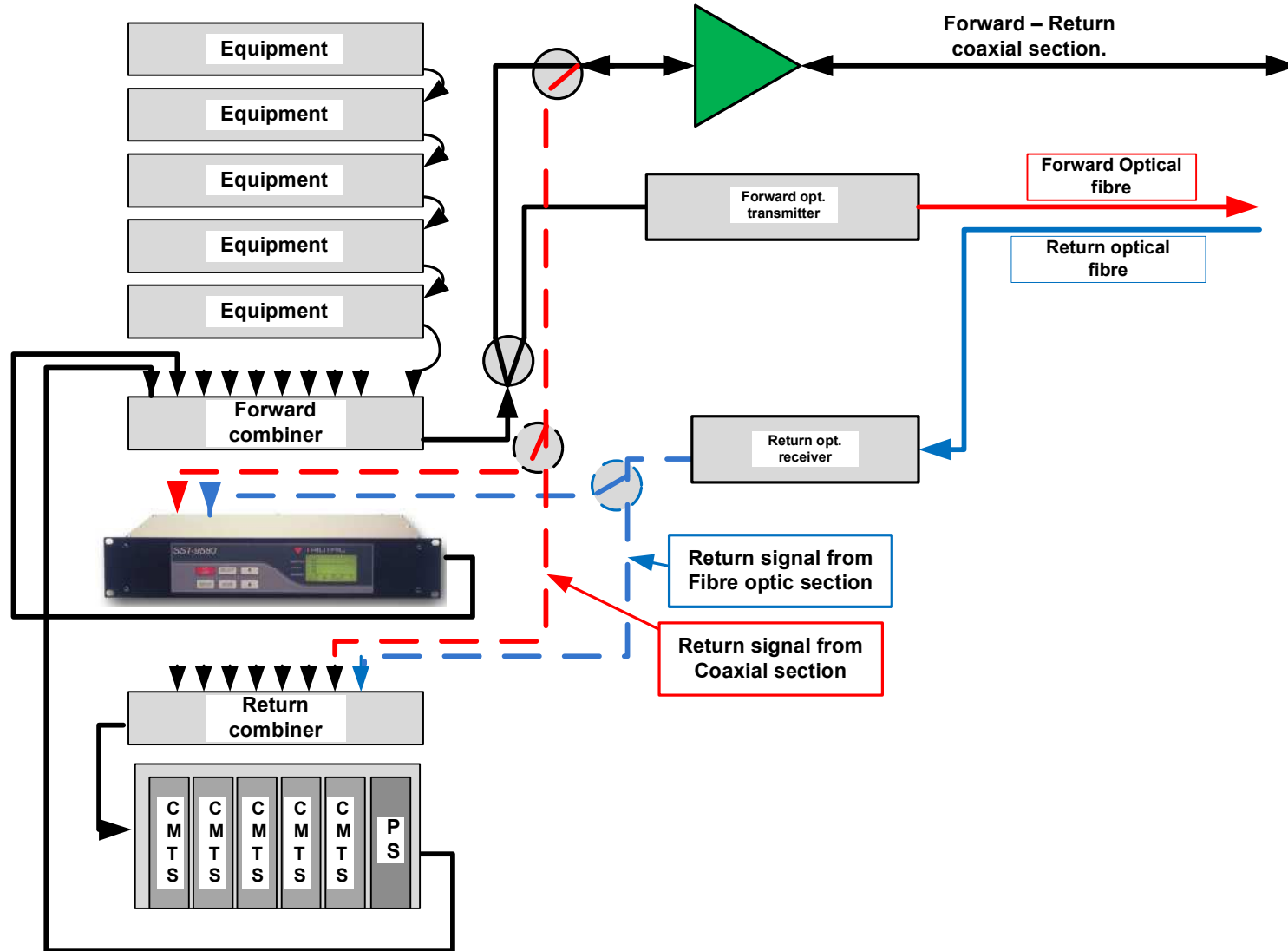

The TRILITHIC 9581-SST

A word about the 9581-SST

The 9581-SST is located at the headend and as the possibility of reading the return signal from 16 NODES or 16 sections of RF AMPLIFIERS.

The 9581-SST is also capable of sending the results of these reading on the forward path of the CATV-HFC system. You need to program a forward frequency for the 9581-SST to communicate with the 860-DHPi located on the system. I like to use 73.5 MHz for the communication frequency, but other are also available.

The return operating frequency of the 9581-SST is from 5 to 65 MHz

The 9581-SST is also equipped with a digitizer that read return signal from 5 to 65 MHz. That way you are able to see the fast response of the return path at the same time on the 860 DHPi.

You can program the 9581-SST to receive 8 frequencies from 5 to 65 MHz and you must not select frequencies used by the CMTS. These frequencies are sent by the 860-DSPi, and are used to adjust the gain and response of the return section. You can select less frequencies but 8 frequencies gives you a better idea of the gain and flatness of the return system.

You also can get INGRESS and NOISE reading with an IP address and a special program installed on a PC thru internet.

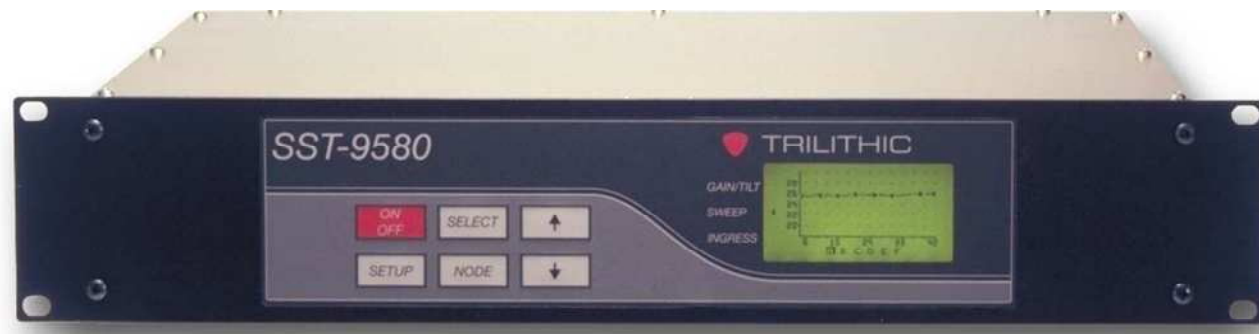

Catv Expert

www.catvexpert.com

The TRILITHIC 860-DHPi

A word about the TRILITHIC 860-DHPi.

The 860 DHPi is a field instrument that is also completely digitized. It operate from 5 to 1,000 MHz and contains many options, that can be added when you purchase the instrument or can also be added at later date.

The only options of the 860 DHPi that will be discussed in this paper are the option SSR and SPECTRUM ANALYZER.

As mentioned before, the 860 DHPi when equipped with the SSR option is capable of sending 8 return frequencies between 5 and 65 MHz It is also capable to receive the result of the return path test is sent by the 9581-SST.

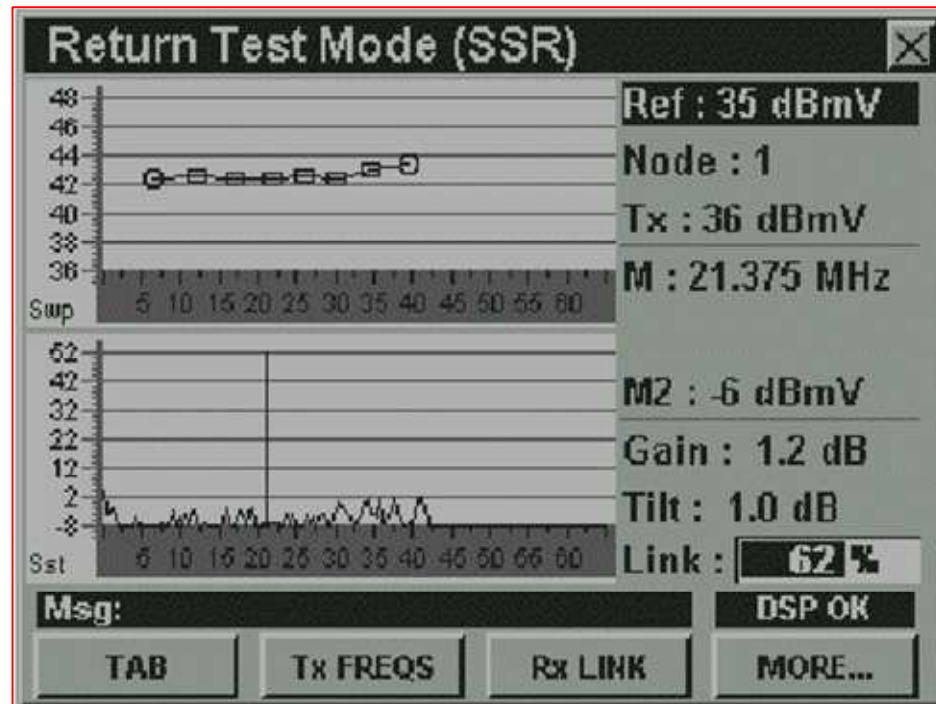

How this return sweep system operates.

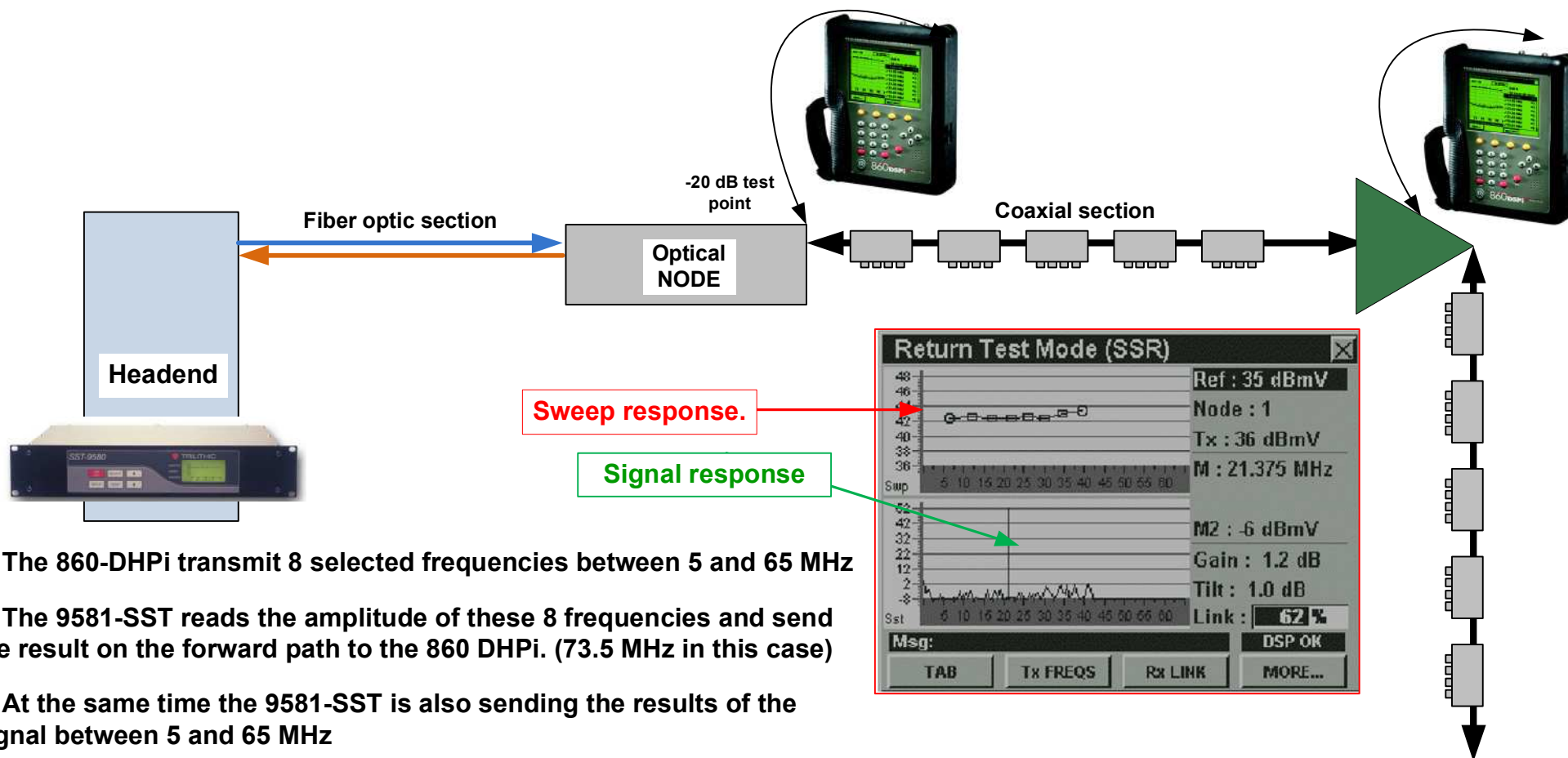

- 1- The 860-DHPi transmit 8 selected frequencies between 5 and 65 MHz
- 2- The 9581-SST reads the amplitude of these 8 frequencies and send the result on the forward path to the 860 DHPi. (73.5 MHz in this case)
- 3- At the same time the 9581-SST is also sending the results of the signal between 5 and 65 MHz
- 4- On the same screen on the 860 DHPi you see the sweep response and the signal of the 5 to 65 MHz section.
- 5- You can also insert a MARKER to help you locate the frequency of the problem and at the same time his amplitude.

How this return sweep system operates.

- 1- Below is an example of eight (8) return signal been sent from the field by the 860-DHPi to the 9581-SST at the headend. These signal are used to adjust the amplitude of the return section of the CATV-HFC system.
- 2- Notice that the two (2) 3.2 MHz wide DOCSIS 2.0 signal are free from any signal sent to the headend unit.
- 3- I also added the CB frequency, that can be causing some problem on some system.

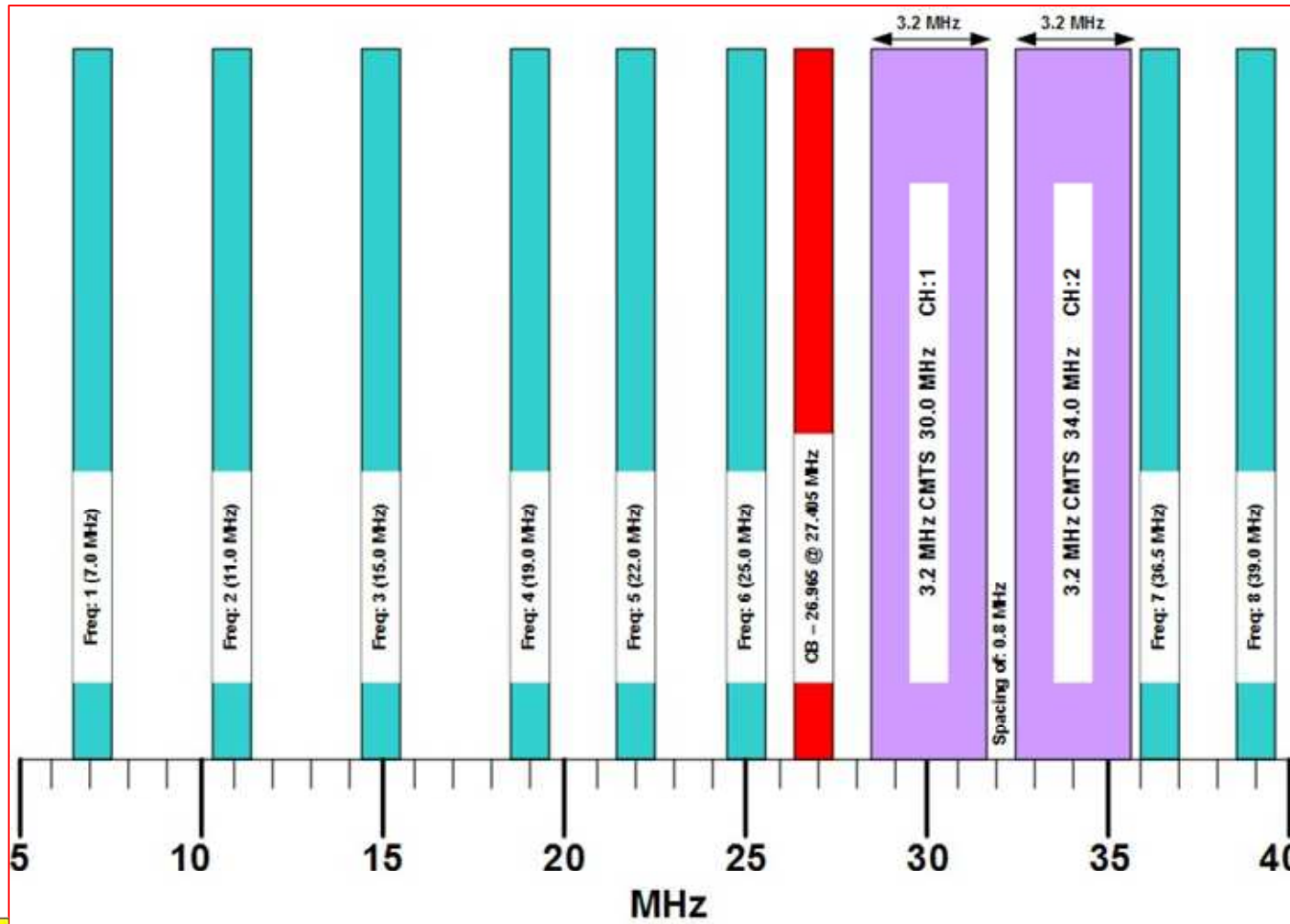

OK..... you have INGRESS or NOISE on your return system.

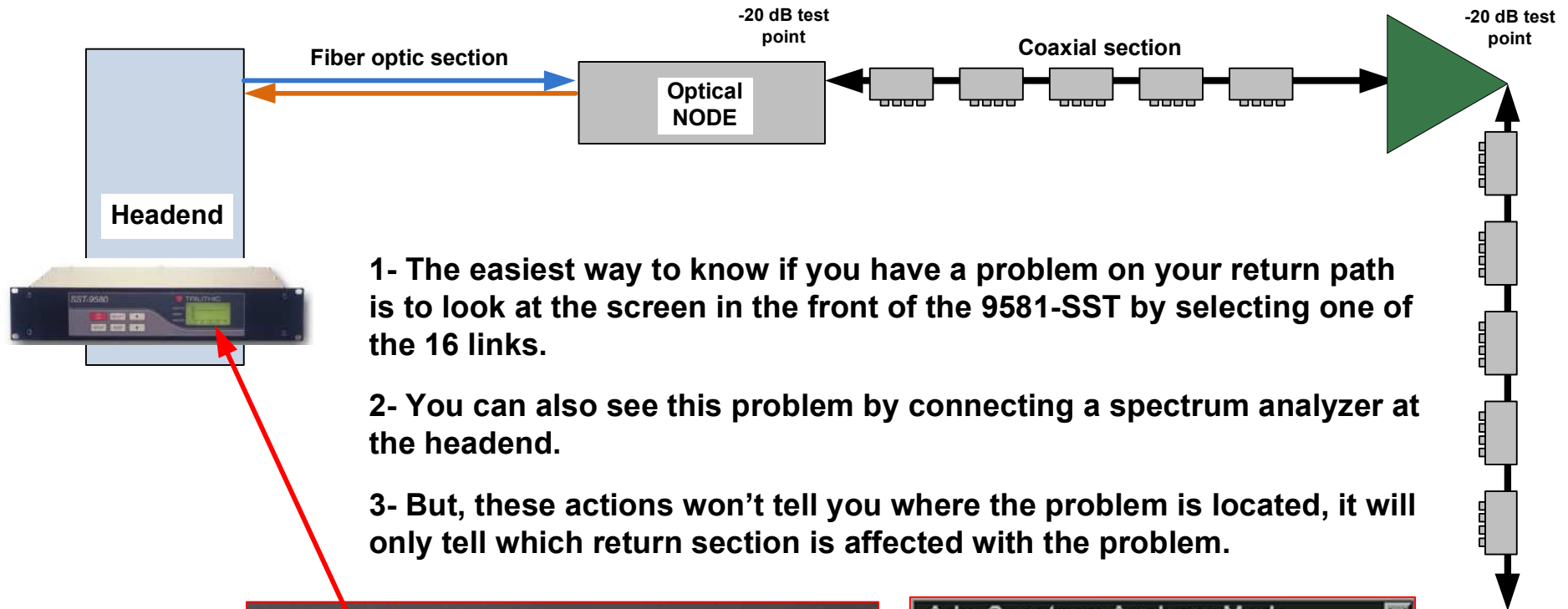

- 1- The easiest way to know if you have a problem on your return path is to look at the screen in the front of the 9581-SST by selecting one of the 16 links.
- 2- You can also see this problem by connecting a spectrum analyzer at the headend.
- 3- But, these actions won't tell you where the problem is located, it will only tell which return section is affected with the problem.

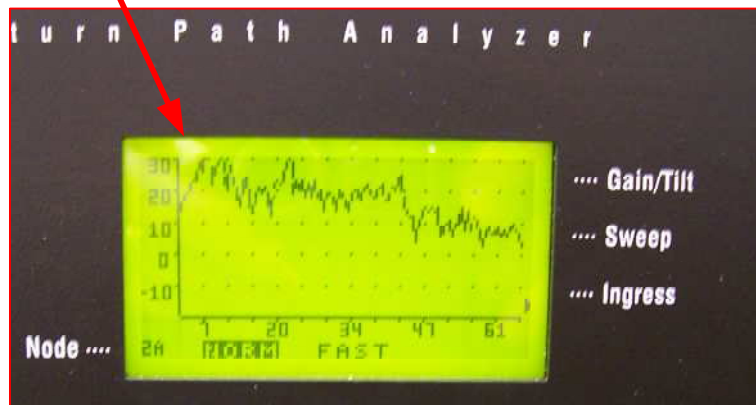

View direct in front of the 9581-SST

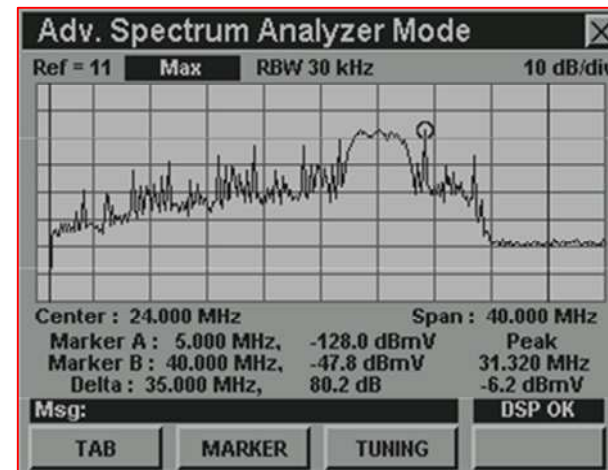

View with a spectrum analyzer at the headend.

Now, you know which portion of the system has a problem, you now have to locate it and remove it.

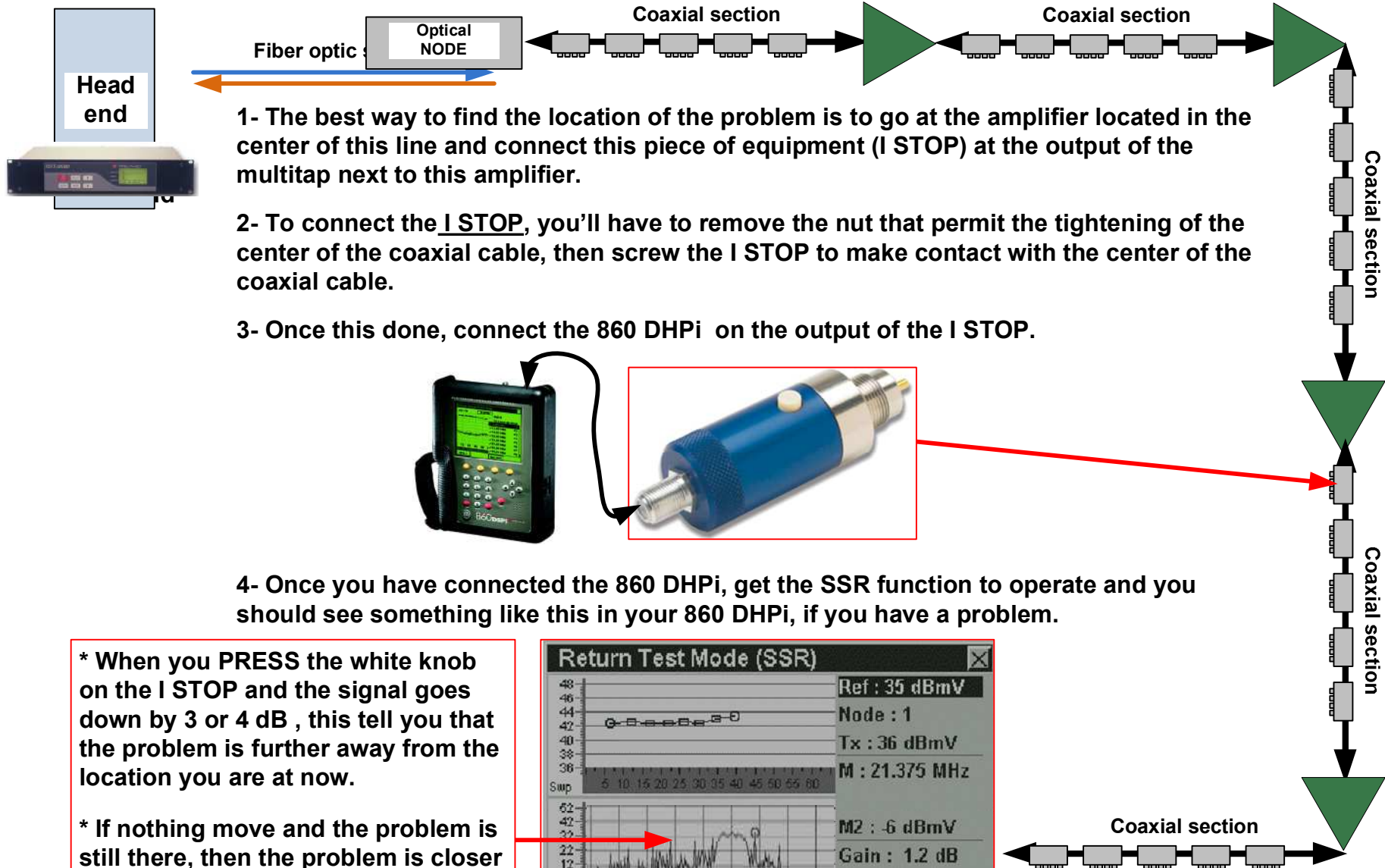

1- The best way to find the location of the problem is to go at the amplifier located in the center of this line and connect this piece of equipment (I STOP) at the output of the multitap next to this amplifier.

2- To connect the I STOP, you'll have to remove the nut that permit the tightening of the center of the coaxial cable, then screw the I STOP to make contact with the center of the coaxial cable.

3- Once this done, connect the 860 DHPi on the output of the I STOP.

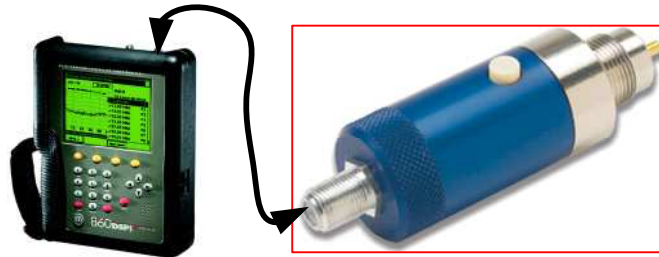

4- Once you have connected the 860 DHPi, get the SSR function to operate and you should see something like this in your 860 DHPi, if you have a problem.

* When you PRESS the white knob on the I STOP and the signal goes down by 3 or 4 dB , this tell you that the problem is further away from the location you are at now.

* If nothing move and the problem is still there, then the problem is closer toward the NODE.

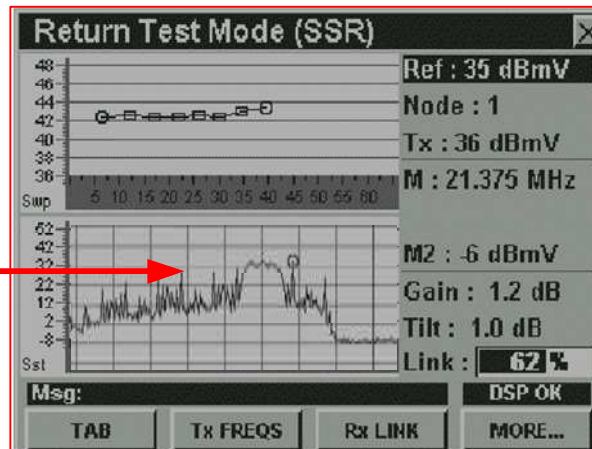

What next.....

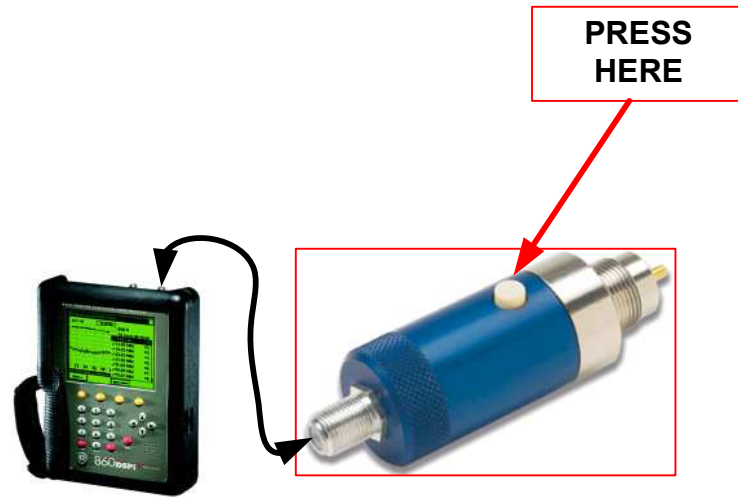

1-By pressing the white button on the I STOP, you should see the INGRESS (in this case) go down by 3 to 4 dB, it also mean that the INGRESS or NOISE problem is after the location you are at now.

2- If the INGRESS does not go down by 3 or 4 dB, it mean the problem is between your present location and the NODE or amplifier(S) feeding this coaxial line.

3- After moving to another location and doing what is explained above, you'll finally get to a location where the signal at the input of a multitap will go down and will not go down at the output of this multitap. You have located the problem area.

4- Now you know that the problem comes from one of the drop connection at this multitap.

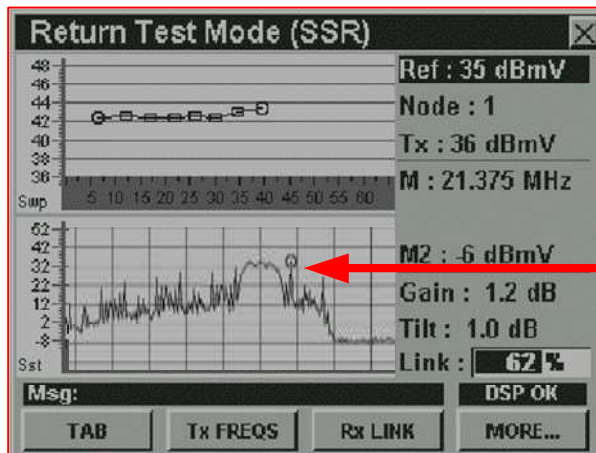

Signal should go down 3 or 4 dB down when trouble is located after your location on the system.

Now that you are at the faulty multitap.

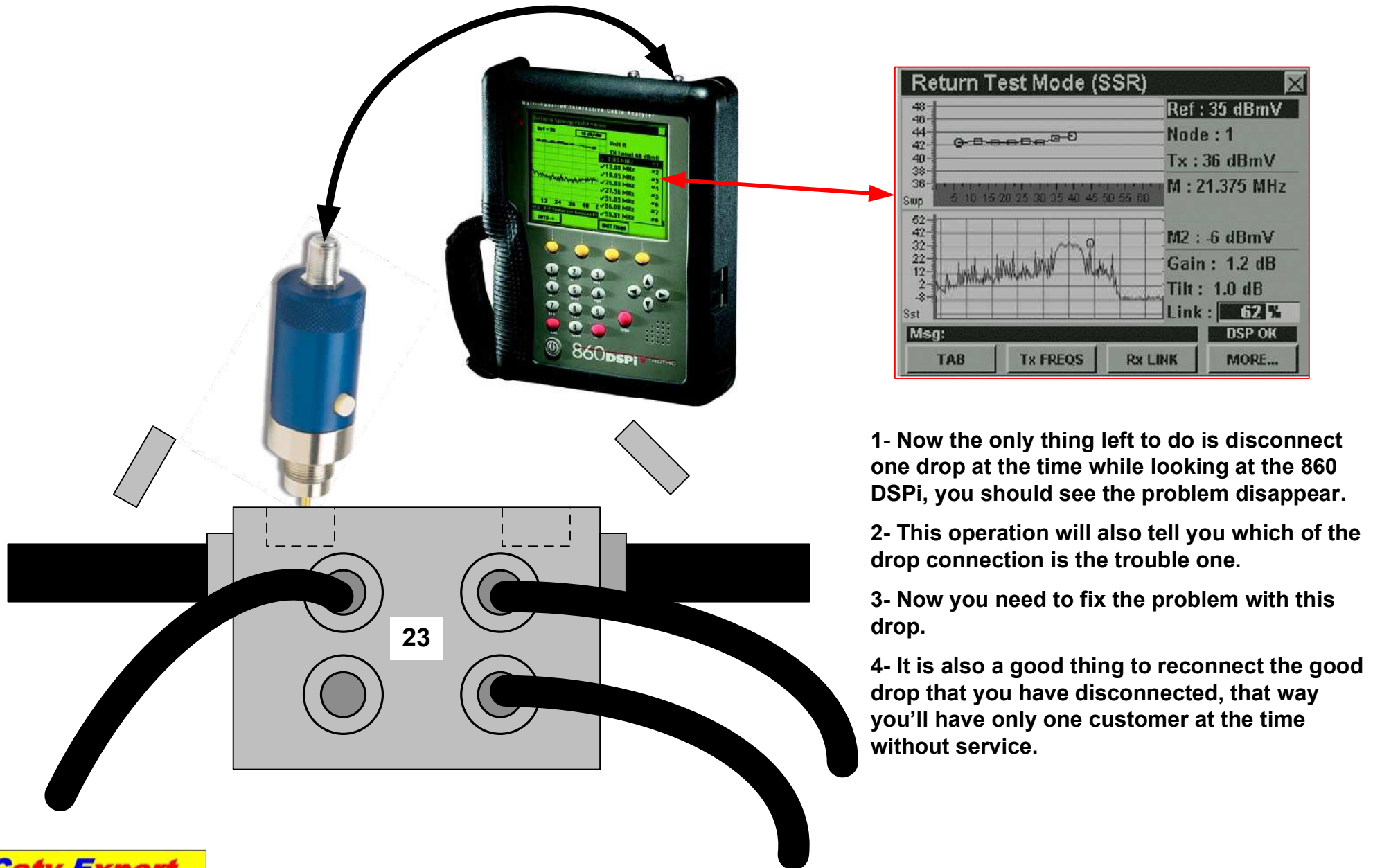

- 1- Now the only thing left to do is disconnect one drop at the time while looking at the 860 DSPi, you should see the problem disappear.
- 2- This operation will also tell you which of the drop connection is the trouble one.
- 3- Now you need to fix the problem with this drop.
- 4- It is also a good thing to reconnect the good drop that you have disconnected, that way you'll have only one customer at the time without service.

Now that you have found the trouble area.

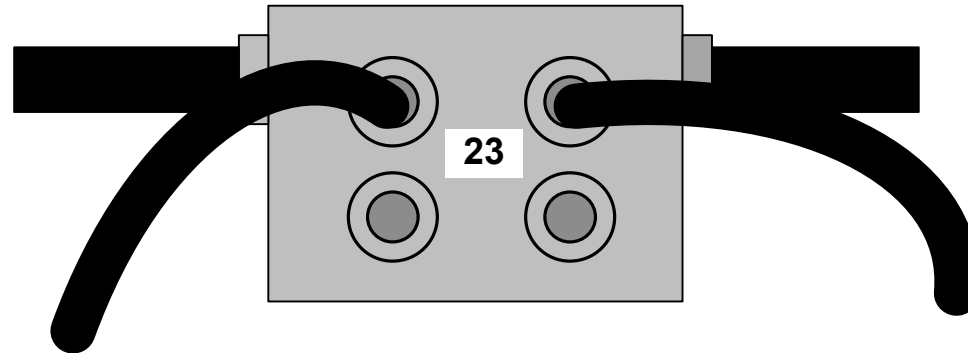

- 1- Now, connect the drop wire with the problem to the input of the 860 DSPi.
- 2- Turn on the 860 DSPi and program the SPECTRIM ANALYZER mode.
- 3- Adjust the passing frequency to read 5 to 40 MHz
- 4- Take a look at the result.

The troubled service drop wire connection.

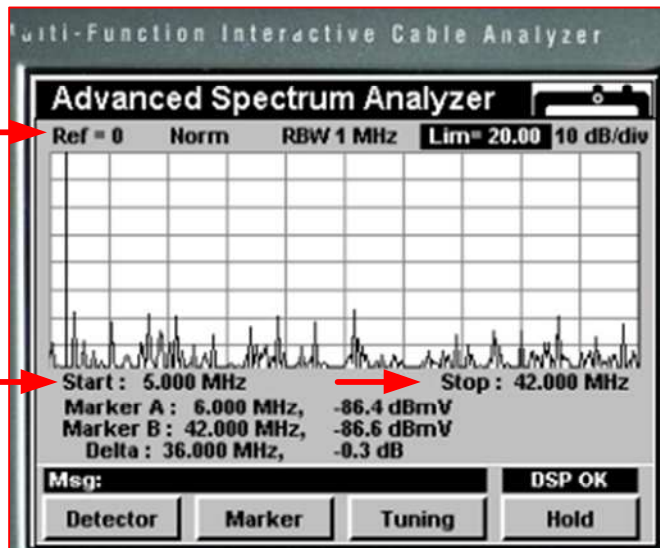

Ref. @ 0 dBmV

Start – End Sweep Freq.

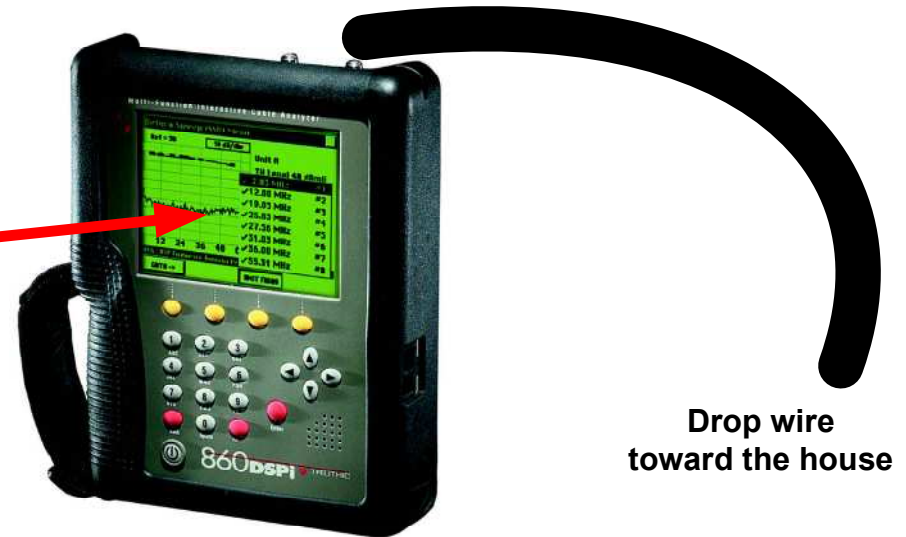

Drop wire toward the house

Catv Expert

www.catvexpert.com

Chasing the problem on the installation.

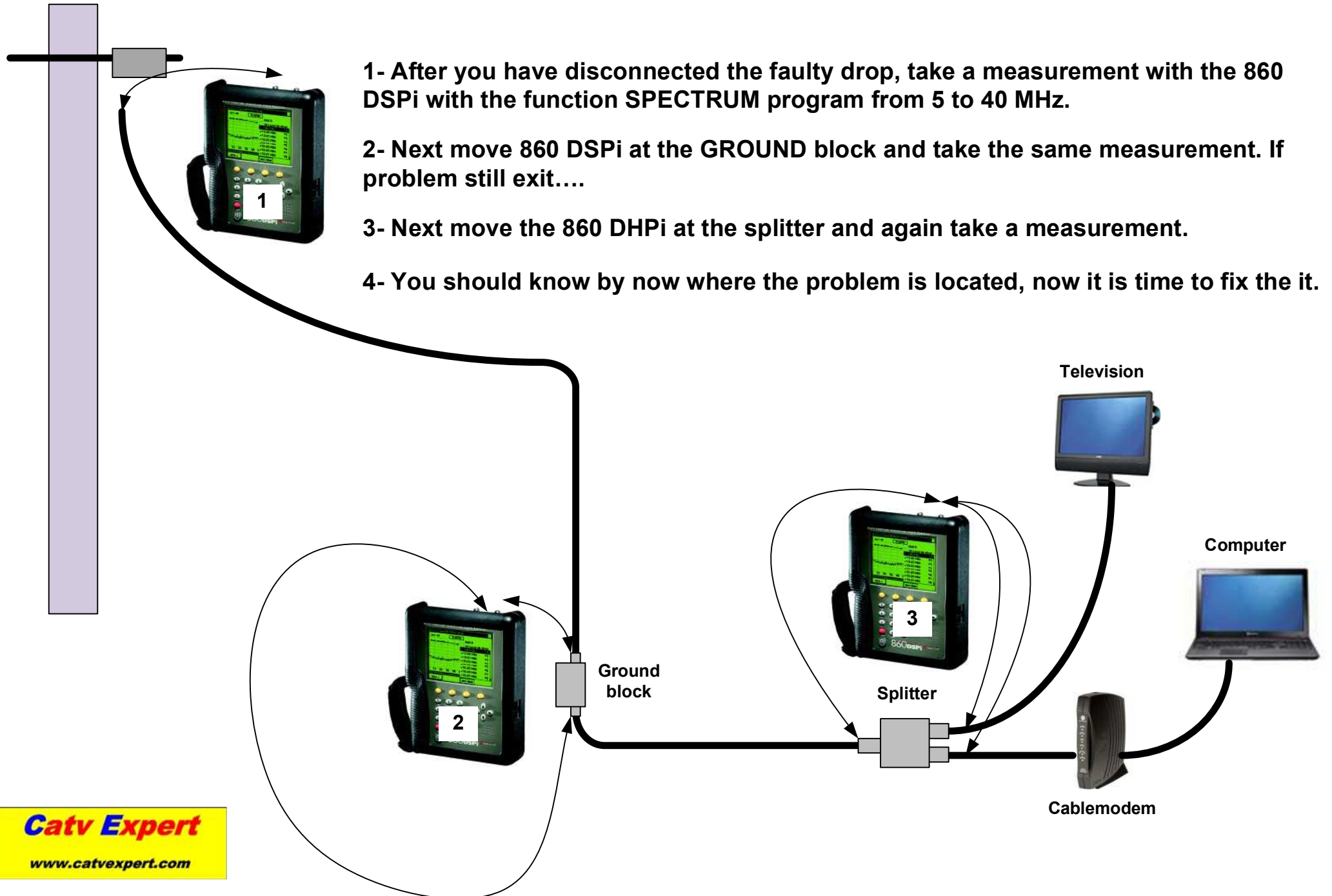

Chasing the problem at the drop wire.

Some cable operator have standard as far as the quality of the customer drop.

They want no interfering signal from 5 to 40 MHz coming from inside the house.

To make such a test, go to SPECTRUM ANALYZER mode, select LIM and move to systems specification (-25 dBmV in this case) and if the drop does not meet this specification, you need to find the problem and repair it.

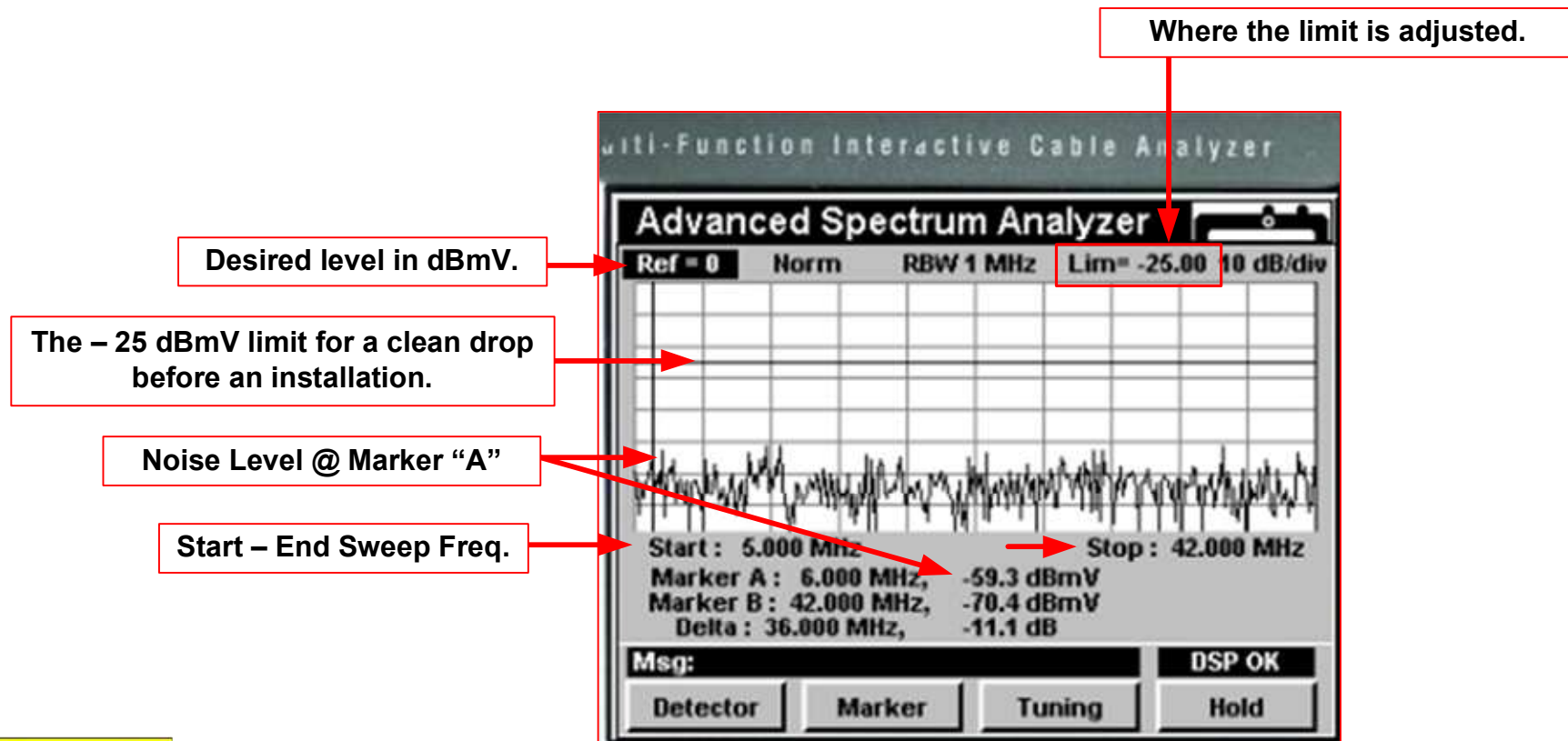

Another way to look for a problem area at distance is using a PC equipped with a software that communicates by INTERNET with a 9581-SST located at the headend.

Since the 9581-SST headend instrument is capable of been addressed by an IP address, you can use that function to get information on the return section of a CATV-HFC system.

Selecting one of the 8 legs.

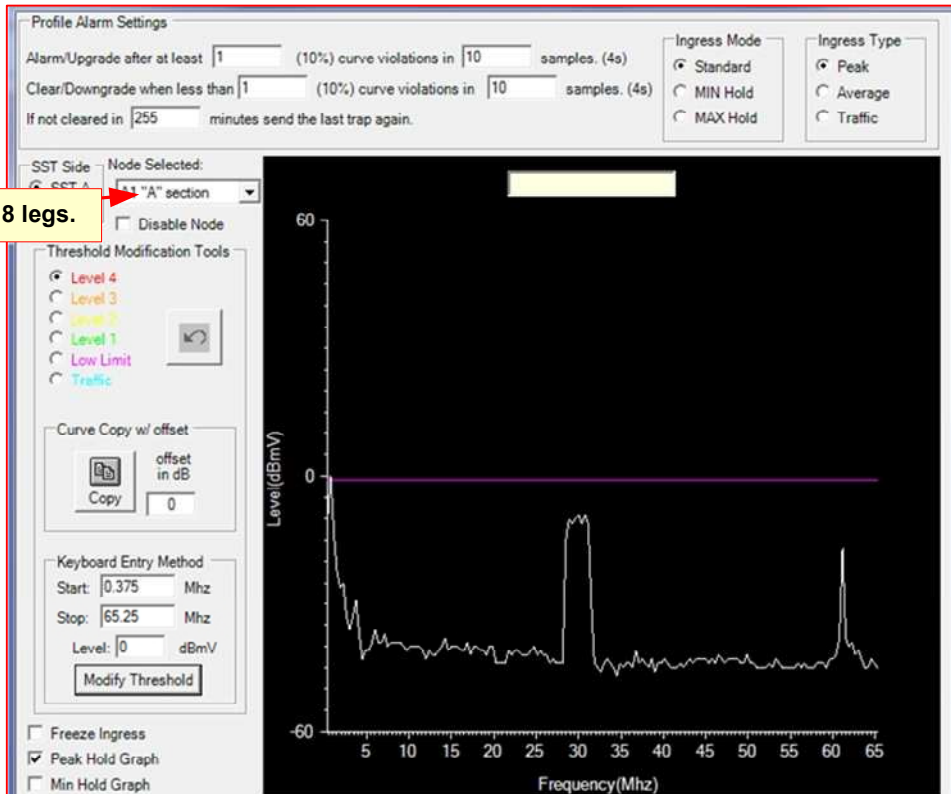

One section without major problem.

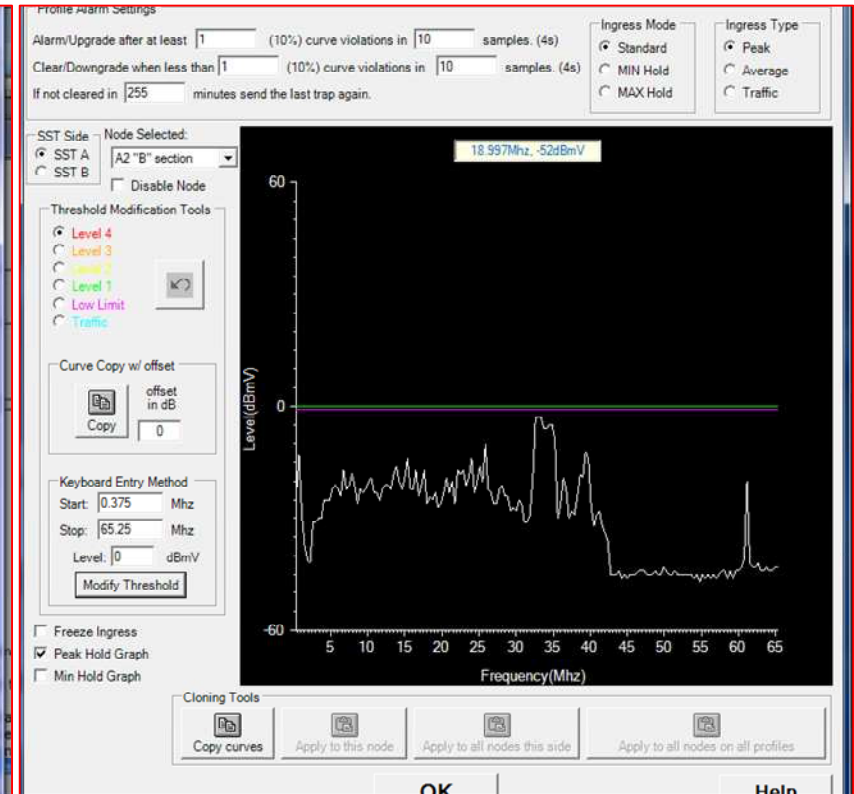

One section with a major problem.

Conclusion.

- * I have shown you “my way” of chasing INGRESS and NOISE on a return section of a CATV-HFC system.
- * I understand that other type of equipment are capable of doing the same procedure, but this is the system I am use to.
- * Remember, working with this solution, you’ll have only one customer out of service at the time.
- * Hope you’ve enjoyed this presentation.
- * If you have any question, please fell free to write to me at:

J. A. André (Andy) Lamarre

Catv Expert

lamarrea@videotron.ca



TO RETURN TO MY WEB SITE, USE THE LEFT ARROW ON TOP OF YOUR BROWSER.

Catv Expert

www.catvexpert.com